

**Bruciatori di gas ad aria soffiata • Forced draught gas burners • Brûleurs gaz à air soufflé
 Gas-Gebläsebrenner • Quemadores de gas de aire soplado**

Gulliver

BS1D COD. 3761550 TIPO/TYP/TYP 915 T1

BS3D COD. 3761750 TIPO/TYP/TYP 917 T1

BS2D COD. 3761650 TIPO/TYP/TYP 916 T1

BS4D COD. 3761850 TIPO/TYP/TYP 918 T1

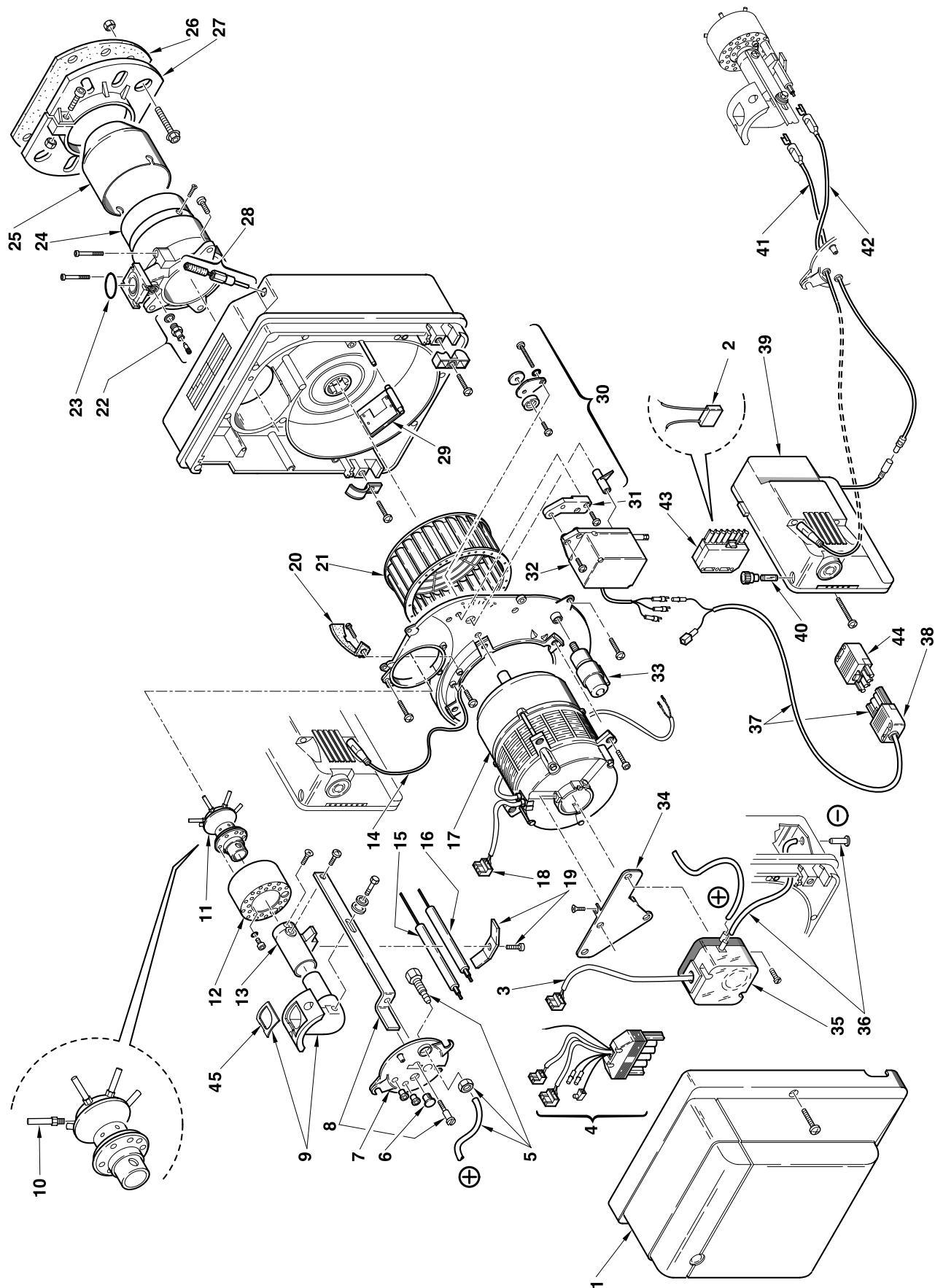

N.	COD.	3761550	3761650	3761750	3761850	DESCRIZIONE	DESCRIPTION	DESCRIPTION	BESCHREIBUNG	DENOMINACIÓN
1	3008080	•				COFANO	COVER	CAPOT	BRENNERHAUBE	ENVOLVENTE
1	3008509		•			COFANO	COVER	CAPOT	BRENNERHAUBE	ENVOLVENTE
1	3007975			•		COFANO	COVER	CAPOT	BRENNERHAUBE	ENVOLVENTE
1	3008496				•	COFANO	COVER	CAPOT	BRENNERHAUBE	ENVOLVENTE
2	3008582	•	•	•	•	CONDENSATORE	CAPACITOR	CONDENSATEUR	KONDENSATOR	CONDENSADOR
3	3007984	•	•	•	•	COLLEGAMENTO	LEAD	CABLE DE CONNEXION	VERBINDUNG	CABLE CONEXIÓN
4	3008933	•	•	•	•	COLLEGAMENTO	LEAD	CABLE DE CONNEXION	VERBINDUNG	CABLE CONEXIÓN
5	3007982	•	•	•	•	RACCORDO E TUBETTO	CONNECTOR AND TUBE	MAMELON ET TUYAU	NIPPEL UND RÖHRCHEN	RACORD Y TUBO
6	3007458	•	•	•	•	VETRINO	VIEWING PORT	REGARD	VERSCHLUßSTOPFEN	MIRILLA
7	3007613	•				COPERCHIO	COVER	COUVERCLE	DÜSENSTOCK-FLANSCH	TAPA
7	3007491		•			COPERCHIO	COVER	COUVERCLE	DÜSENSTOCK-FLANSCH	TAPA
7	3007642			•	•	COPERCHIO	COVER	COUVERCLE	DÜSENSTOCK-FLANSCH	TAPA
8	3007980	•	•			STAFFA E VITE	BRACKET AND SCREW	SUPPORT ET VIS	DÜSENSTOCKHALTERUNG	SOPORTE ARRASTRE Y TORNILLO
8	3007981			•		STAFFA E VITE	BRACKET AND SCREW	SUPPORT ET VIS	DÜSENSTOCKHALTERUNG	SOPORTE ARRASTRE Y TORNILLO
8	3008505				•	STAFFA E VITE	BRACKET AND SCREW	SUPPORT ET VIS	DÜSENSTOCKHALTERUNG	SOPORTE ARRASTRE Y TORNILLO
9	3007977	•				GOMITO	ELBOW	COUDE	GASSCHLITTEN	CODO
9	3007978		•			GOMITO	ELBOW	COUDE	GASSCHLITTEN	CODO
9	3007979			•	•	GOMITO	ELBOW	COUDE	GASSCHLITTEN	CODO
10	3008000	•				TUBO	TUBE	TUYAU	GASKOPF-DÜSEN	TUBO
10	3008001		•			TUBO	TUBE	TUYAU	GASKOPF-DÜSEN	TUBO
10	3008002			•		TUBO	TUBE	TUYAU	GASKOPF-DÜSEN	TUBO
10	3008504				•	TUBO	TUBE	TUYAU	GASKOPF-DÜSEN	TUBO
11	3007996	•				DISTRIBUTORE	DISTRIBUTOR	DISTRIBUTEUR	GASKOPF	DISTRIBUIDOR
11	3007997		•			DISTRIBUTORE	DISTRIBUTOR	DISTRIBUTEUR	GASKOPF	DISTRIBUIDOR
11	3007998			•		DISTRIBUTORE	DISTRIBUTOR	DISTRIBUTEUR	GASKOPF	DISTRIBUIDOR
11	3008503				•	DISTRIBUTORE	DISTRIBUTOR	DISTRIBUTEUR	GASKOPF	DISTRIBUIDOR
12	3007993	•				TAZZA	AIR DIFFUSER	DIFFUSEUR D'AIR	STAUSCHEIBE	DIFUSOR DEL AIRE
12	3007994		•			TAZZA	AIR DIFFUSER	DIFFUSEUR D'AIR	STAUSCHEIBE	DIFUSOR DEL AIRE
12	3007995			•		TAZZA	AIR DIFFUSER	DIFFUSEUR D'AIR	STAUSCHEIBE	DIFUSOR DEL AIRE
12	3008501				•	TAZZA	AIR DIFFUSER	DIFFUSEUR D'AIR	STAUSCHEIBE	DIFUSOR DEL AIRE
13	3007990	•				PROLUNGA GOMITO	ELBOW EXTENSION	PROLONGE COUDE	STAUSCHEIBEIBENHALTER	PROLONGACIÓN CODO
13	3007991		•			PROLUNGA GOMITO	ELBOW EXTENSION	PROLONGE COUDE	STAUSCHEIBEIBENHALTER	PROLONGACIÓN CODO
13	3007992			•	•	PROLUNGA GOMITO	ELBOW EXTENSION	PROLONGE COUDE	STAUSCHEIBEIBENHALTER	PROLONGACIÓN CODO
14	3007989	•	•	•	•	COLLEGAMENTO	LEAD	CABLE DE CONNEXION	VERBINDUNG	CABLE CONEXIÓN
15	3007987	•				SONDA	PROBE	SONDE	IONISATIONSELEKTRODE	SONDA
15	3007988		•	•	•	SONDA	PROBE	SONDE	IONISATIONSELEKTRODE	SONDA
16	3008930	•				ELETTRODO	ELECTRODE	ELECTRODE	ZÜNDELEKTRODE	ELECTRODO
16	3008931		•	•		ELETTRODO	ELECTRODE	ELECTRODE	ZÜNDELEKTRODE	ELECTRODO
16	3008932			•		ELETTRODO	ELECTRODE	ELECTRODE	ZÜNDELEKTRODE	ELECTRODO
17	3008489	•	•			MOTORE	MOTOR	MOTEUR	MOTOR	MOTOR
17	3008492			•		MOTORE	MOTOR	MOTEUR	MOTOR	MOTOR
17	3008506				•	MOTORE	MOTOR	MOTEUR	MOTOR	MOTOR
18	3007454	•	•	•	•	PRESA MOTORE	MOTOR SOCKET	PRISE MOTEUR	STECKDOSE FÜR MOTOR	CONECTOR MOTOR
19	3007265	•	•	•	•	CAVALLOTTO	U BOLT	CAVALIER	HALTEBÜGEL	SOPORTE FIJACIÓN
20	3007475	•	•			CONVOGLIATORE	SUCTION DUCT	CONVOYEUR D'AIR	LUFTLEITBLECH	GUÍA
20	3007651			•		CONVOGLIATORE	SUCTION DUCT	CONVOYEUR D'AIR	LUFTLEITBLECH	GUÍA
20	3008552				•	CONVOGLIATORE	SUCTION DUCT	CONVOYEUR D'AIR	LUFTLEITBLECH	GUÍA

N.	COD.	3761550	3761650	3761750	3761850	DESCRIZIONE	DESCRIPTION	DESCRIPTION	BESCHREIBUNG	DENOMINACIÓN
21	3007476	•	•			GIRANTE	FAN	TURBINE	GEBLÄSERAD	TURBINA
21	3007652			•		GIRANTE	FAN	TURBINE	GEBLÄSERAD	TURBINA
21	3008494			•	•	GIRANTE	FAN	TURBINE	GEBLÄSERAD	TURBINA
22	3005447	•	•	•	•	GRUPPO MISURAZIONE	TEST POINT	PRISE DE PRESSION	MESSNIPPEL	GRUPO TOMA DE PRESIÓN
23	3008003	•				ANELLO DI TENUTA	O-RING SEAL	JOINT D'ETANCHEITE	O-RING-DICHTUNG	JUNTA TÓRICA
23	3008004		•			ANELLO DI TENUTA	O-RING SEAL	JOINT D'ETANCHEITE	O-RING-DICHTUNG	JUNTA TÓRICA
23	3008005			•	•	ANELLO DI TENUTA	O-RING SEAL	JOINT D'ETANCHEITE	O-RING-DICHTUNG	JUNTA TÓRICA
24	3008006	•				MANICOTTO	MANIFOLD	MANCHON	FLAMMKOPF MIT GASANSCHLUß	COLLARÍN
24	3008007		•			MANICOTTO	MANIFOLD	MANCHON	FLAMMKOPF MIT GASANSCHLUß	COLLARÍN
24	3008008			•		MANICOTTO	MANIFOLD	MANCHON	FLAMMKOPF MIT GASANSCHLUß	COLLARÍN
24	3008502				•	MANICOTTO	MANIFOLD	MANCHON	FLAMMKOPF MIT GASANSCHLUß	COLLARÍN
25	3008009	•				IMBUTO FIAMMA	END CONE	EMBOUT GUEULARD	FLAMMROHR	TUBO LLAMA
25	3008010		•			IMBUTO FIAMMA	END CONE	EMBOUT GUEULARD	FLAMMROHR	TUBO LLAMA
25	3008011			•		IMBUTO FIAMMA	END CONE	EMBOUT GUEULARD	FLAMMROHR	TUBO LLAMA
25	3008498				•	IMBUTO FIAMMA	END CONE	EMBOUT GUEULARD	FLAMMROHR	TUBO LLAMA
26	3002698	•				SCHERMO	GASKET	JOINT ISOLANT	KESSELFLANSCH-DICHTUNG	JUNTA AISLANTE
26	3005795		•			SCHERMO	GASKET	JOINT ISOLANT	KESSELFLANSCH-DICHTUNG	JUNTA AISLANTE
26	3005813			•		SCHERMO	GASKET	JOINT ISOLANT	KESSELFLANSCH-DICHTUNG	JUNTA AISLANTE
26	3008500				•	SCHERMO	GASKET	JOINT ISOLANT	KESSELFLANSCH-DICHTUNG	JUNTA AISLANTE
27	3008013	•				FLANGIA MOBILE	MOVABLE FLANGE	BRIDE MOBILE	KESSELFLANSCH	BRIDA MOVIBLE
27	3008014		•			FLANGIA MOBILE	MOVABLE FLANGE	BRIDE MOBILE	KESSELFLANSCH	BRIDA MOVIBLE
27	3008015			•		FLANGIA MOBILE	MOVABLE FLANGE	BRIDE MOBILE	KESSELFLANSCH	BRIDA MOVIBLE
27	3008493				•	FLANGIA MOBILE	MOVABLE FLANGE	BRIDE MOBILE	KESSELFLANSCH	BRIDA MOVIBLE
28	3007517	•				REGOLATORE SERRANDA	AIR DAMPER REGULATOR	SYSTEME REGLAGE D'AIR	LUFTREGULIERUNG	REGULADOR REGISTRO AIRE
28	3007499		•			REGOLATORE SERRANDA	AIR DAMPER REGULATOR	SYSTEME REGLAGE D'AIR	LUFTREGULIERUNG	REGULADOR REGISTRO AIRE
28	3007648			•	•	REGOLATORE SERRANDA	AIR DAMPER REGULATOR	SYSTEME REGLAGE D'AIR	LUFTREGULIERUNG	REGULADOR REGISTRO AIRE
29	3007519	•				SERRANDA ARIA	AIR DAMPER	VOLET D'AIR	LUFTKLAPPE	REGISTRO DEL AIRE
29	3007840		•			SERRANDA ARIA	AIR DAMPER	VOLET D'AIR	LUFTKLAPPE	REGISTRO DEL AIRE
29	3007650			•		SERRANDA ARIA	AIR DAMPER	VOLET D'AIR	LUFTKLAPPE	REGISTRO DEL AIRE
29	3008497				•	SERRANDA ARIA	AIR DAMPER	VOLET D'AIR	LUFTKLAPPE	REGISTRO DEL AIRE
30	3008027	•				LEVISMI 1° STADIO	1st STAGE LINKAGE	RACCORDS 1ère ALLURE	LUFTREGULIERUNG 1. Stufe	PALANCAS REGIS. AIRE PRIM. ETAPA
30	3008028		•			LEVISMI 1° STADIO	1st STAGE LINKAGE	RACCORDS 1ère ALLURE	LUFTREGULIERUNG 1. Stufe	PALANCAS REGIS. AIRE PRIM. ETAPA
30	3008029			•		LEVISMI 1° STADIO	1st STAGE LINKAGE	RACCORDS 1ère ALLURE	LUFTREGULIERUNG 1. Stufe	PALANCAS REGIS. AIRE PRIM. ETAPA
30	3008507				•	LEVISMI 1° STADIO	1st STAGE LINKAGE	RACCORDS 1ère ALLURE	LUFTREGULIERUNG 1. Stufe	PALANCAS REGIS. AIRE PRIM. ETAPA
31	3008030	•	•	•	•	SUPPORTO	SUPPORT	SUPPORT	HALTERUNG	SOPORTE
32	3008031	•	•	•	•	APRISERRANDA	AIR DAMPER OPENER	OUVRE - VOLET AIR	LUFTKLAPPENSTELLMOTOR	MOTOR REGISTRO AIRE
33	3007479	•	•			CONDENSATORE 4 µF	CAPACITOR 4 µF	CONDENSATEUR 4 µF	KONDENSATOR 4 µF	CONDENSADOR 4 µF
33	3007655			•		CONDENSATORE 6,3 µF	CAPACITOR 6.3 µF	CONDENSATEUR 6,3 µF	KONDENSATOR 6,3 µF	CONDENSADOR 6,3 µF
33	3008499				•	CONDENSATORE 8 µF	CAPACITOR 8 µF	CONDENSATEUR 8 µF	KONDENSATOR 8 µF	CONDENSADOR 8 µF
34	3008018	•	•	•	•	STAFFA	BRACKET	SUPPORT	HALTEBLECH	SOPORTE
35	3007423	•				PRESSOSTATO ARIA	AIR PRESSURE SWITCH	PRESSOSTAT AIR	LUFTDRUCKWÄCHTER	PRESÓSTATO AIRE
35	3007444		•	•	•	PRESSOSTATO ARIA	AIR PRESSURE SWITCH	PRESSOSTAT AIR	LUFTDRUCKWÄCHTER	PRESÓSTATO AIRE
36	3008017	•	•	•	•	RACCORDO E TUBETTO	CONNECTOR AND TUBE	MAMELON ET TUYAU	NIPPEL UND RÖHRCHEN	RACORD Y TUBO
37	3008934	•	•	•	•	COLLEGAMENTO	LEAD	CABLE DE CONNEXION	VERBINDUNG	CABLE CONEXIÓN
38	3006949	•	•	•	•	PRESA A 4 POLI	4 POLE SOCKET	PRISE 4 POLES	4 - POLIGE STECKDOSE	CONECTOR HEMBRA DE 4 CONTAC.
39	3001176	•	•	•	•	APPARECCHIATURA 568	CONTROL BOX 568	BOITE DE CONTR. 568	STEUERGERÄT 568	CAJA DE CONTROL 568
40	3007396	•	•	•	•	FUSIBILE	FUSE	FUSIBLE	FEINSICHERUNG	FUSIBLE

